

Product Information

Temperature Transmitter PMT50Ex-2 /-3



PROFIBUS

- **Signal conditioning – linearisation – output characteristic transformation**
- **Input for resistance and Potentiometer or RTD Pt100/Pt1000 and thermocouples**
- **Measuring range programmable**
- **Linearisation or transformation of output characteristic via 32 base-points programmable**
- **Automatic input fault detection**

Characteristics

The programmable Temperature Transmitter PMT50 operates with RTD and thermocouple input signals. The device convert the signal to analog output 0/4..20 mA; 0/2..10 V DC. Optional a serial interface is available. The device offers a linearisation function for any sensor curves and a simulator function. The integrated transmitter supply 24 V DC max. 30 mA allows the feeding of 2-and 3-wire sensors. 4 alarm outputs for monitoring and controlling are available.

Technical data

Power supply

Supply voltage : 230 V AC ±10 %
 115 V AC ±10 %
 24 V DC ±15 %
 Um = 253 V AC or 125 V DC (terminals 11 and 13)

Power consumption : < 5 VA
 Operating temperature : -10..+55 °C
 CE-conformity : ATEX-directive 2014/34/EU
 Standards : EN 60079-0:2006 EN60079-11:2007
 EN 61241-0:2006 EN61241-11:2006
 EMC-directive / standard : 2014/30/EU / EN 61326-1:2013

Explosion protection

Marking : II (1) G [Ex ia] IIC/IIB bzw. II (1) D [Ex iaD]
 Approval : TÜV 08 ATEX 554329

Device type 2

Input : resistance 0..20 kΩ (terminals 35, 36, 37, 38)

Fault detection : broken line

Accuracy : < 0.2 %, ±1 Digit

Max. U₀ no load : 1.4 V

Max. I₀ short circuit : 2,5 mA

Max. output power P₀ : 3 mW

Resistance : 5600 Ω

Characteristic curve : trapezoidal

Internal inductivity : 4 µH

Internal capacity : 135 nF

Explosion protection **Ex ia/IIC** **ia/IIB**

Max. external inductivity : 100 mH 100 mH

Max. external capacity : 25 µF 120 µF

Input : Potentiometer min. 1 kΩ..max. 100 kΩ (terminals 45, 47, 48)

Accuracy : <0.2 %, ±1 Digit

Max. values U₀ : 9.6 V

Max. I₀ : 56 mA

Max. P₀ : 200 mW

Resistance R : 259 Ω

Characteristic curve : trapezoidal

Internal inductivity : 4 µH

Internal capacity : negligible

Explosion protection **Ex ia/IIC** **ia/IIB**

Max. external inductivity : 5 mH 20 mH

Max. external capacity : 0.48 µF 2 µF

Device type 3

Input : Pt100 (3-wire) -100.0..+600.0 °C
 Pt1000 (3-wire) -100.0..+300.0 °C
 thermocouple (TC)
 type J -100.0..+800.0 °C
 type K -150..+1200 °C
 type N -150..+1200 °C
 type S -50..+1600 °C (terminals 35, 36, 37; 45, 47)

Fault detection : broken line (Pt100 / Pt1000,TC) or short circuit (only Pt100 / Pt1000)

Accuracy : < 0.1 %, ±1 Digit

Max. voltage no load U₀ : 1,4 V

Max. short circuit curr. I₀ : 2.5 mA

Max. output power P₀ : 3 mW

Resistance R : 5600 Ω

Characteristic curve : trapezoidal

Internal inductivity : 4 µH

Internal capacity : 135 nF

Explosion protection **Ex ia/IIC** **ia/IIB**

Max. external inductivity : 100 mH 100 mH

Max. external capacity : 25 µF 120 µF

Outputs

Alarm outputs : relay SPDT
 < 250 V AC < 250 VA < 2 A
 cos Phi ≥ 0.3
 < 300 V DC < 40 W <2 A (terminals 21, 22, 23; 25, 26, 27)

Analog output : 0/4..20 mA burden ≤ 500 Ω
 0/2..10 V burden > 500 Ω, isolated
 output changes automatically (burden depending)

- Accuracy : 0.2 %; TK 0.01 % / K (terminals 17, 18)

Fault function : for broken line or short circuit detection
 → analog output (programmable)
 0 mA, < 3.6 mA or >21.5 mA
 → alarm relays
 min. or max. programmable

Bus system

Modbus : RS485, RTU or ASCII
 max. 38400 Baud

Profibus : Profibus DP

Connection : 9 pole D-SUB plug in the front

Display : graphic-LCD-display, 128 x 64 Pixel with white LCD backlight

Product Information

Case : Polyamide (PA) 6.6, UL94V-0
 TS35 acc. to DIN EN 60715
Weight : approx. 450 g
Connection : screw terminals 0.14..2.5 mm²
 AWG 26..AWG14
Protection class : case IP30, terminals IP20 acc. to
 BGV A3

Dimensions

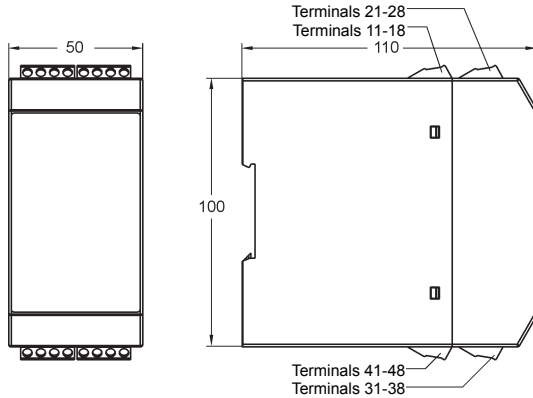

Bus connection

Modbus		
PIN	Signal	EIA / TIA-485 Name
5	D1	B / B'
9	D0	A / A'
1	Common	C / C'
Profibus		
3	RxD / TxD-P	
5	DGND	
6	VP / +5V max. 10 mA	
8	RxD / TxD-N	

9 pol. D-Sub plug
 in the front

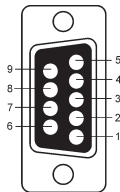

Connection diagram

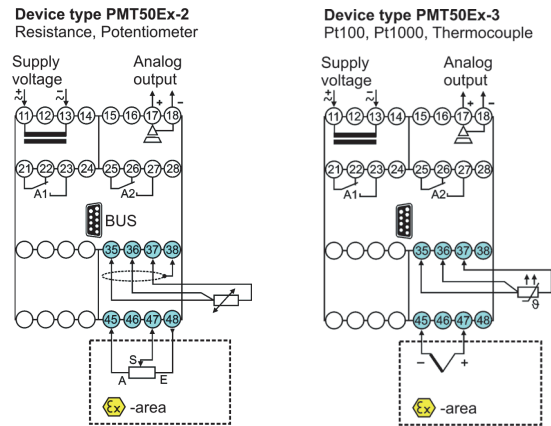

Ordering code

PMT50Ex - 1. - 2. - 3. - 4. - 5. - 6.

1. Device type/input	
2	Resistance in the range 0..20 kΩ Poti 1 kΩ..100 kΩ
3	RTD Pt100, 3-wire, -100.0..+600.0 °C RTD Pt1000, 3-wire, -100.0..+300.0 °C Thermocouple J (Fe-CuNi), -100.0..+800.0 °C K (NiCr-Ni), -150..+1200 °C N (NiCrSi-NiSi), -150..+1200 °C S (Pt10Rh-Pt), -50..+1600 °C
	Inputs intrinsically safe EX II (1) G [Ex ia] IIC/IIB EX II (1) D [Ex iaD]
2. Analog output	
AO	0/4..20 mA, 0/2..10 V DC isolated
3. Alarm outputs	
00	not installed
2R	2 relay outputs, A1, A2 SPDT
4. BUS configuration	
00	not installed
MB	Modbus RTU/ASCII, RS485
PB	Profibus DP
5. Supply voltage	
0	230 V AC, ± 10 % 50-60 Hz
1	115 V AC, ± 10 % 50-60 Hz
5	24 V DC, ± 15 %
6. Options	
00	without option